

# Horizon

CUTTING

# PC-640

## HIGH QUALITY CUTTING WITH SIMPLE OPERATION



### BENEFITS

#### ACCURATE CUTTING

The backgauge enables you to adjust the cutting length accurately within 0.5 mm or 0.019".

#### CUT LINE

The LED cutting line shows the actual cutting position to allow easy and accurate positioning and operation.

#### SAFETY

The PC-640 employs updated safety standards. Two button operation, safety cover, and emergency stop features for operator safety.

# SIMPLE AND SAFE OPERATION SUITABLE FOR OFFICE USE.

## EASY OPERATION

Clamp the stock by turning the pressure handle by hand, and press the two cutting buttons. The backgauge can be adjusted by 0.5 mm or 0.019" by turning the positioning handle. The backgauge can be locked when you repeat the same cutting position.

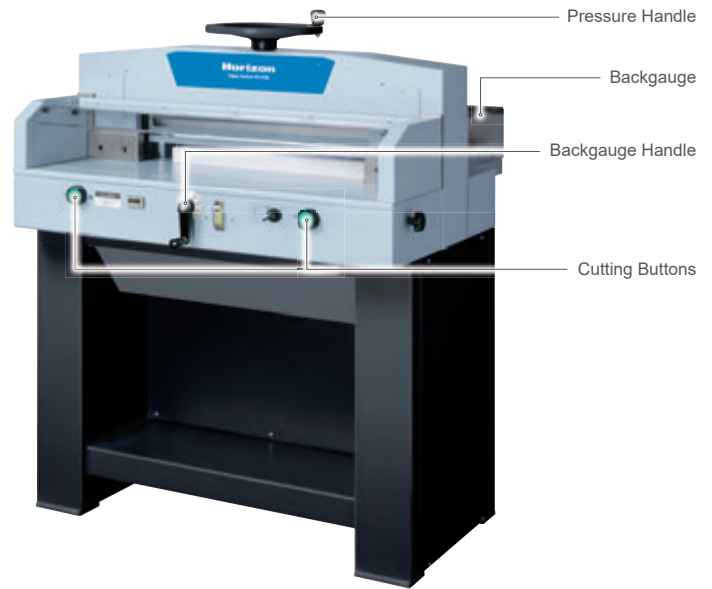
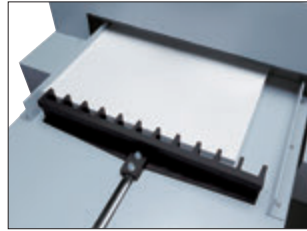

## OPERATOR SAFETY

### ■ Double Safety Circuit

The system is further equipped with a hard-wired secondary safety interrupt for operator safety.

### ■ Safety Mechanism

The machine does not operate when the front cover is opened. Also, if either of the two cutting buttons is released during the cutting operation, the machine will be stopped immediately.

### ■ Key Switch

The Power switch is key-activated to limit user access.

## COUNTER

Cut cycles are indicated on a digital counter. It helps to determine when the cutting knife should be sharpened or replaced.

## SPECIFICATIONS.

PC-640		
Cutting Width		Max. 640 mm or 25.19"
Cutting Height		Max. 70 mm or 2.75"
Cutting Depth		Max. 640 mm or 25.19" Min. 20 mm or 0.79"
Clamp System and Pressure	Manual Max. About 10 kN (1,000 kgf)	
Cutting Speed	3.3 seconds per cycle (50 Hz) 2.8 seconds per cycle (60 Hz)	
Voltage / Frequency	Single Phase 115 V, 50 or 60 Hz Single Phase 230 V, 50 or 60 Hz	
Machine Dimensions	W1,070 × D1,185 × H1,315 mm or W42.2" × D46.7" × H51.8"	

## Machine Dimension (Unit : mm / inch)

Height : 1,315 / 51.8"

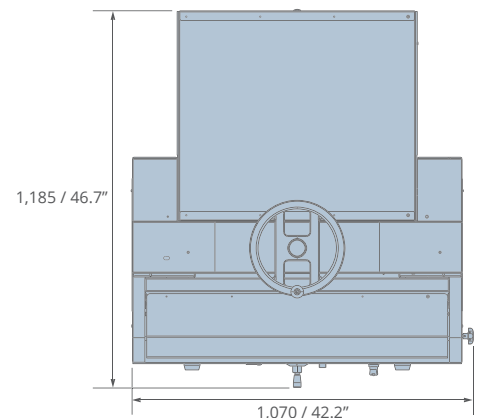

## Horizon

Horizon International Inc.

1601 Asahi, Shinasahicho, Takashima,  
Shiga, 520-1501, Japan  
Phone : +81-740-25-4570  
Fax : +81-740-25-5820  
www.horizon.co.jp

Horizon GmbH

Pascalstrasse 20  
25451 Quickborn / Germany  
Phone : +49 4106 8042-0  
Fax : +49 4106 8042-199  
www.horizon.de

**MORE AT**  
**HORIZON.CO.JP**

