

**Horizon**

**PF-39**

# Precious Fold

## in Table-top Paper Folder



**Max. Sheet Width**  
365 mm (14.3")

**Capable to Feed**  
Coated Paper with hand feeding

**Max. 350 sheets/min.**  
(A4 / 8.5" x 11" Single Fold)

**Heavy Duty**  
Casting Structure of Roller Bearing

# 350 sheets per minute. Top level in the class.

## ● Features

- Maximum folding speed is 350 sheets/min. (A4 / 8.5" x 11" - single fold)
- Maximum sheet width is 365 mm (14.3").
- The roller bearings are housed in the casting structure for superior folding accuracy and stability.
- User-friendly operation. Sheet size and fold pattern are set-up with a button.
- Roller gap adjustment allows to fold a wide range of sheet.
- Coated paper can be folded with hand-feeding.
- Easy jammed sheet removal and roller cleaning.
- Sheet feeding and delivery is performed on the same side for efficient operation.
- Preset and pose functions are available.

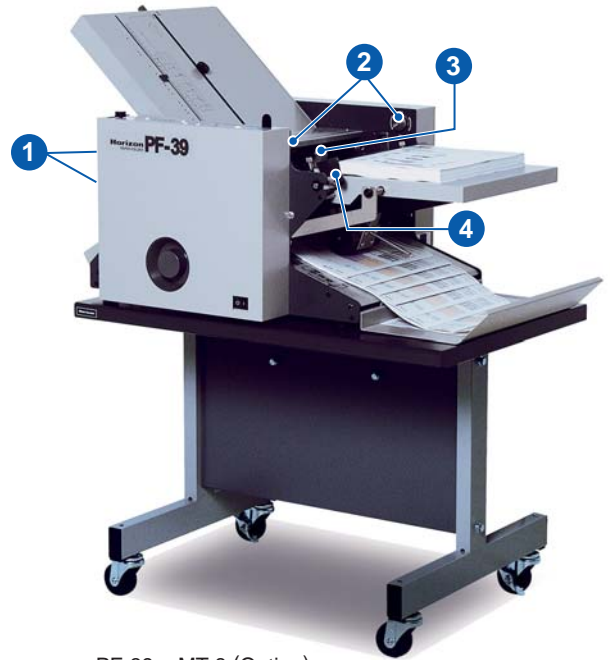

PF-39 + MT-8 (Option)

### Fine Adjustments

- ① Roller Gap Adjustment for folding a wide range of sheet from heavy to thin paper.
- ② Feed Pressure Adjustment for feeding up to 157 gsm paper.
- ③ Pad Gap Adjustment for cross fold.
- ④ Skew Adjustment to correct skew in folding.

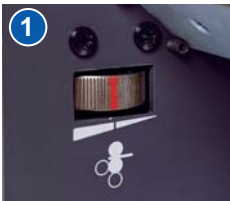

Roller Gap Adjustment



Feed Pressure Adjustment



Pad Gap Adjustment



Skew Adjustment

### Simple Maintenance

Jammed sheet removal or roller cleaning can be performed easily, without any special tools.

Photo : Fold buckle being removed.



### PF-39 Major Specifications

Sheet Size	Max. 365(W) x 610(L) mm (14.37" x 24.01") (Single or double parallel fold only for sheet which length is 610 mm (24.01"))		
	A3, A4 size for any fold patterns		
	Min. 90(W) x 128(L) mm (3.55" x 5.04") (Single fold only for sheet which length is 128 mm (5.04"))		
Sheet Weight Range	53 to 157 gsm		
Maximum Pile Height	Max. 30 mm (1.1") (Ex. 370 sheets 64 gsm)		
Fold Patterns	Single Fold, Double Parallel Fold, Short Fold, Accordion Fold, Letter Fold, Open Gate Fold		
Production Speed	350 sheets/min. (A4 / 8.5" x 11" - Single Fold)		
Other Function	Total Counter (Up to 9,999) / Preset Stop Counter (Up to 9,999) / Preset Pause Counter (Pause time : 9 steps from 1 to 9)		
Voltage / Frequency	Single Phase 115 V, 60 Hz 220 V, 60 Hz 230 V, 50 / 60 Hz		
Rated Current	Single Phase 115 V	60 Hz	1.3 A
	Single Phase 220 V	60 Hz	0.6 A
	Single Phase 230 V	50 / 60 Hz	0.5 A
Heat Output	540 kJ (130 kcal)		
Motors	50 W x 1		
Machine Dimensions	880(W) x 560(D) x 530(H) mm (34.7" x 22.1" x 20.9")		
Noise Level	L <sub>A</sub> peak : 87.5 dB, L <sub>Aeq</sub> : 83.9 dB		
Machine Weight	56 kg (123.5 lb)		

### PF-39 Options

#### Table / MT-8

Convenient table with wheel.

#### Feed Roller

Up to 3 rollers can be attached. (Factory Option)

The machine design and specifications are subject to change without any notice.

Distributed by

HORIZON INTERNATIONAL, INC.

510 Kuze Ooyabu-cho, Minami-ku, Kyoto, 601-8206, Japan Phone : +81-(0)75-934-6700, Fax : +81-(0)75-934+6708, www.horizon.co.jp