

**Horizon**

# CABS4000S

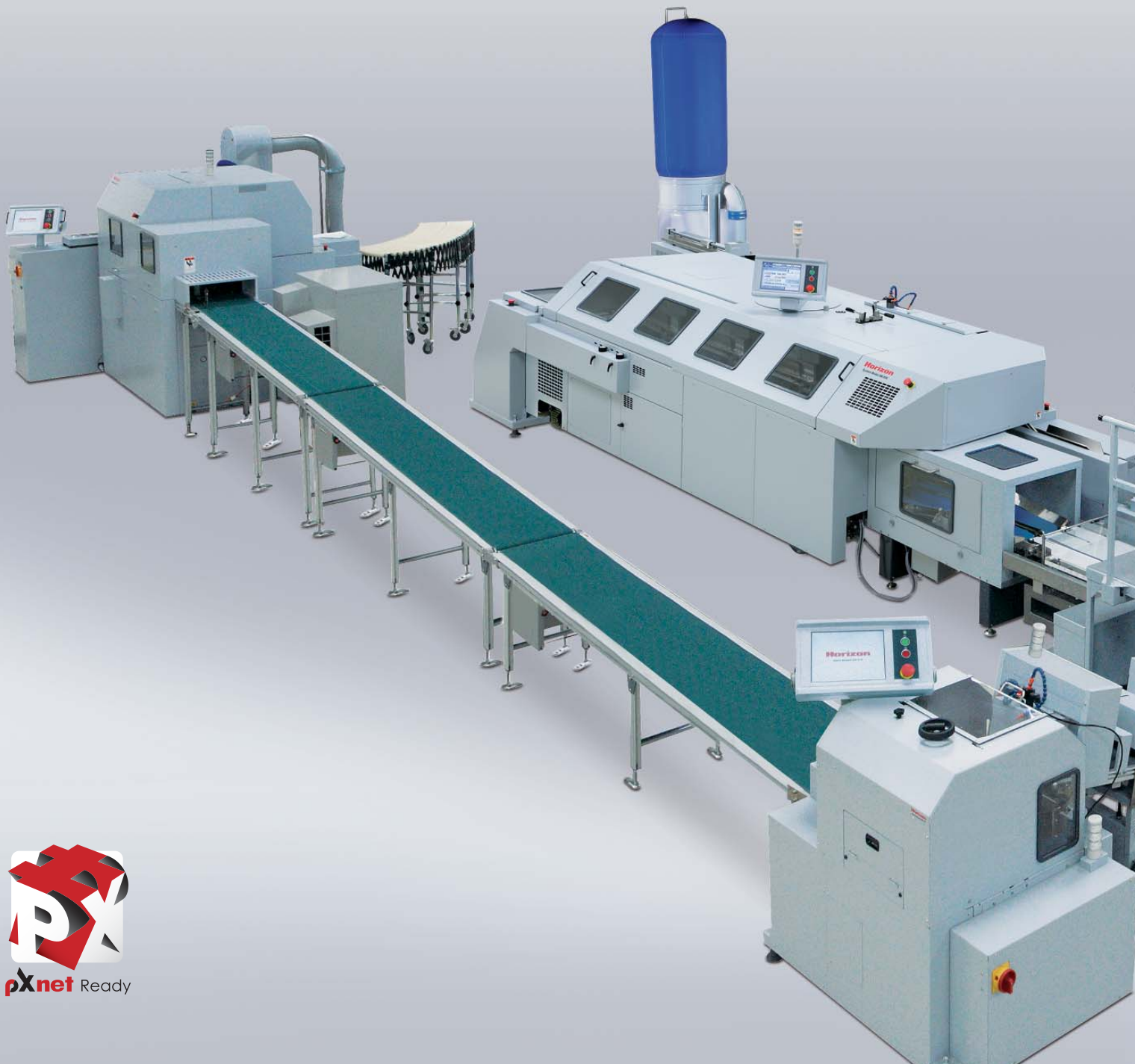

pxnet Ready

The space-efficient CABS4000S binder combines high-performance automation, simplicity of operation, superior productivity, and absolute quality control for short, medium and longer run lengths.

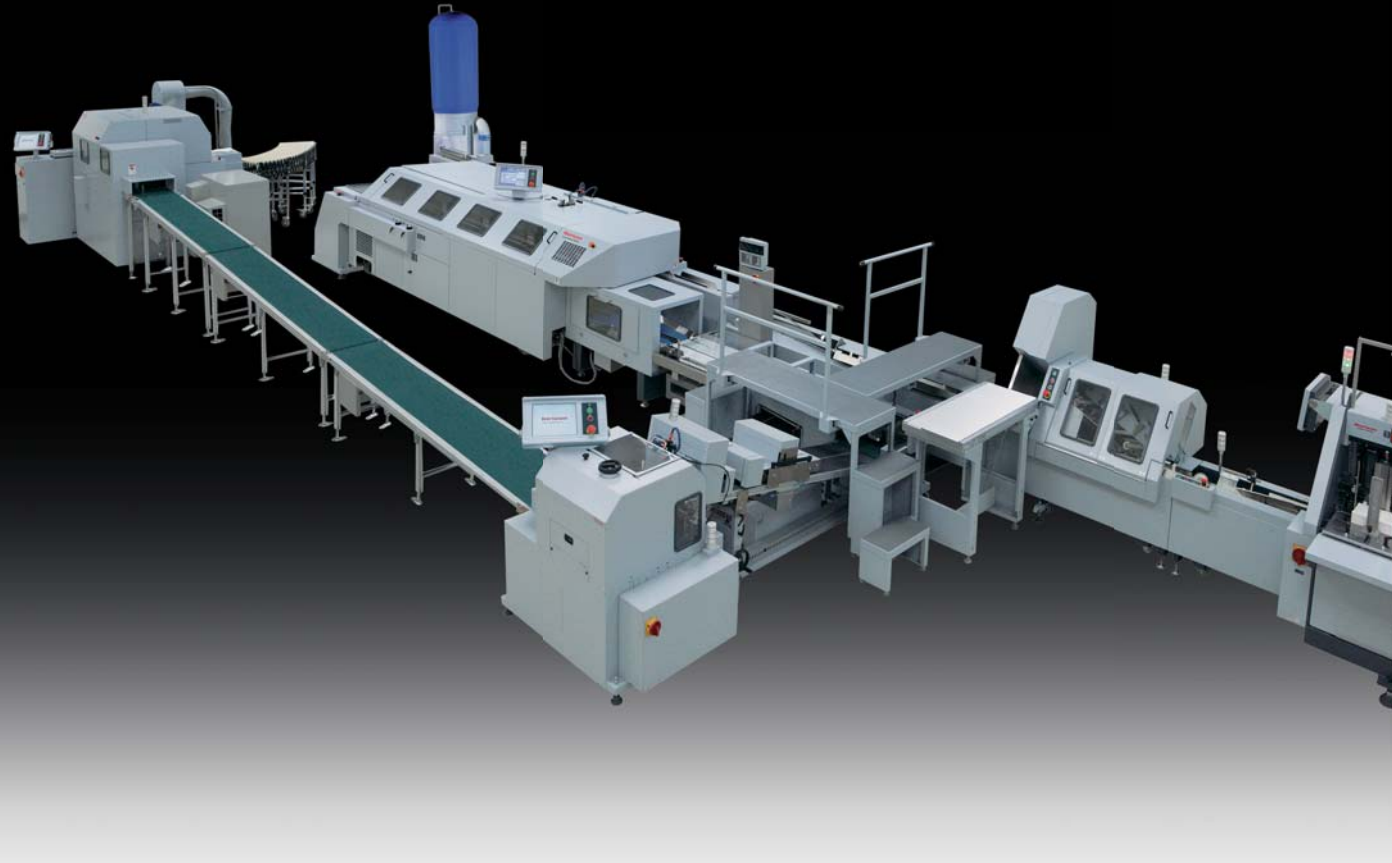

### CABS4000S Features

1. High productivity at 4,000 books/hour with in-line system from gathering to trimming.
2. Color touch screens provide easy, intuitive operation for fast, accurate changeovers and quick adjustments for production flexibility.
3. Equipped with interchangeable tank unit that allows binding with both EVA and PUR hotmelt.
4. Various book sizes can be bound in-line, from minimum size A6 to maximum size A4.
5. Off-line signature gathering is possible using the ST-600 stacker. Also, by installing the RU-600 misfeed unit the gatherer can operate non-stop.
6. Quality control image checking cameras, thickness detector, weight checker and other optional quality control features.
7. The Horizon bindery management system (pXnet) can also be added, for further to increase in efficiency and effectiveness of the binding process. The pXnet is ready to receive JDF data.

# MG-600

System Gatherer



1. Combine up to 6 gathering units for a total of 36 stations.
2. Intuitive operation via intelligent touch screen control.
3. Image checking cameras (option IC-MG600) detect sheets that have been improperly positioned or misprinted.
4. Used stations and settings of the detecting sensor can be memorized.
5. The ST-600 on/off-line stacker allows gathering to be performed off-line from the binder.

Option

#### Book block thickness detector (TD-600)

For enhanced quality control, the book block thickness is measured so that only good books proceed to the next steps. Set-up is done through the intuitive touch screen.



#### Operation section

Large color touch screens are used on each unit for efficient operation. Settings on a gatherer can be memorized in job memory.



#### Feeding section

Stable paper feeding is provided. Each feed station is equipped with a status indicator lamp.



Option

#### Image checker (IC-MG600)

Image checking camera checks the image on each feed cycle to prevent incorrect signature or sheet feeding, for absolute document integrity. The captured image is shown on each display for visual confirmation.



Option

#### Book block rejecting unit (RU-600)

RU-600 rejects any incorrectly collated signatures so the whole system can run non-stop, for maximum productivity.

Option

#### On/Off-line stacker (ST-600)

The MG-600 can run as a stand alone gatherer when the ST-600 stacker is installed.



Option

#### Hand feed unit for MG-600H (HF-600)

HF-600 allows an operator to feed additional signatures or sheets. The MG-600 starts collating when the signature is hand fed, so that both signatures combine smoothly.



# SB-09S

## System Binder



1. Highly accurate automated set-up is performed with simple and easy operation.
2. Book production of up to 4,000 books/hour can be achieved.
3. Both EVA hotmelt and PUR hotmelt are supported by using the interchangeable melt tanks.
4. Two application rollers ensure superior penetration of hotmelt glue.

### Cover feeding section

Press roller style cover feeding grips the cover firmly for stable cover feeding. Any double-feeds are detected by a super-sonic sensor. Covers can be loaded while running.



### Cover feeding / Scoring section

The cover scoring wheels can create up to 4 score lines, and can be automatically set up according to the book thickness.



### Nipping section

A superior nipping system exerts powerful nipping pressure to create strong, durable binds with sharp spine corners. Nipper height and width can be adjusted during operation.



### Delivery section



Book blocks are delivered smoothly from the clamper to the delivery section thanks to the space efficient vertical conveyor. Support guides automatically set according to book thickness. A gentle lay down conveyor insures a high quality bind with accurate spine corners. If a registration error is detected, the book is automatically rejected to the optional reject conveyor.



#### Option

### Book/Cover sheet size input interface (SI-17)

All necessary setups can be automatically performed by reading the length of the actual book block and cover, instead of having to manually input the size data into the operation panel.



### Melt tank section

Two application rollers promote superior penetration of hotmelt glue into the book for stronger binds. Spine and side glue adjustment is done through the touch screen.

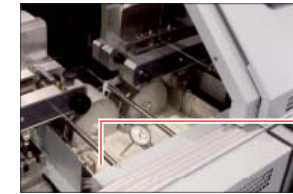

### Milling section

The notching pitch can be also adjusted through the touch screen.



### Book block feed section

Clamp opening width according to the book thickness can be adjusted on all clamps using a lever in a range of about 1 cm (0.39"). (Adjustment range depends on position of the lever.) Sufficient work space and safety covers are provided.

### Operation console

Large color touch screen provides simple and easy operation. All necessary set-ups can be performed through the touch screen.



### In-feed section

Gathered signatures are checked by a height detecting sensor installed on the docking conveyor unit DC-600, and inserted into the clamper while being jogged.



### Melt tank unit for EVA glue

### Melt tank unit for PUR glue (Open drum)

Interchangeable melt tanks allow both EVA hotmelt and PUR hotmelt to be used.



#### Option

### Pre-melt tank

Glue is pre-melted in a separate, high-capacity tank and fed into the glue tank as needed. Pre-melt tanks for EVA hotmelt (PM-20II) and for PUR hotmelt are available.

### Connected delivery section

#### Option

### Stack stream unit (SS-110)

Bound books are transported into the stack stream orientator (SS-110) to accumulate a predetermined number of books (up to 100 mm) for trimming in HT-110. SS-110 is set up automatically according to the setting data from HT-110. Fine adjustment is performed through a large touch screen. The speed of the conveyor to HT-110 is also adjusted automatically.

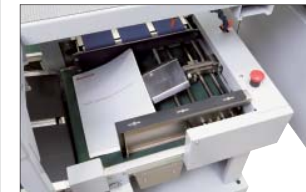

#### Option

### Weight checking unit (WD-17)/Book rejecting unit (RU-17)

The weight checking system detects any books that are missing a cover or signature, and delivers the errored books into a reject tray.



# HT-110

## Three-knife Trimmer



1. Highly accurate set-ups are performed with easy and simple operation.
2. Trimming cycle can be adjusted in 13 stages from 400 to 1,600 cycles/hour. By accumulating 3 books at once at the stream stack orientator, productivity of 4,000 books/hour can be achieved.
3. Rigid framing and durable structure provides the utmost in trimming accuracy.

### Operation console

The trimmer is simple and easy to operate, with all necessary settings performed through the large, icon-based color touch screen. If the system has an error, the error type and location are indicated for quick resolution.



### Option

#### Chip extractor (TB-100)

The three-knife trimming waste is extracted by the chip extractor.



### In-Feed section

A pressing unit in the in-feed section compresses the books to remove air for reduced bulk and accurate trimming.



### Option

#### Plate for trimming for each size

Clamper plate and cutting table for each size are available as options.

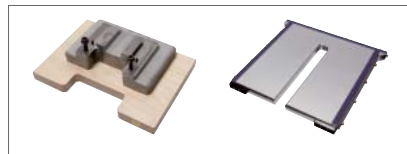

### Chuck plate recognition device



LED lamps light up to indicate which chuck plate is suitable for each book size. Replacement of the chuck plate is fast and easy.



### Trimming section



The height of each knife and the angle of the fore-edge knife can be adjusted through the color touch screen during operation. Trimmings are blown away from the knife by strong air nozzles mounted on the knife holders.



## Advanced Features

### PUR

## Strong, Environmentally Friendly PUR Solution

Polyurethane Reactive, also called PUR, is a polyurethane adhesive attracting attention for binding strength and eco-friendliness.

### Strong and Lay-Flat Binding

As the printing industry diversifies, there is growing demand for binding with color printed sheets. EVA hotmelt glue has difficulty binding coated stock firmly, and does not currently enable acceptable lay-flat binding. However, PUR hotmelt glue can provide adequate binding strength and lay-flat quality for both offset and digital prints.



EVA

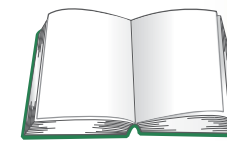

PUR

PUR hotmelt glue provides the best page spread compared to traditional EVA hotmelt glue. High binding strength allows for the application of a small amount of glue, allowing the pages to lay flat when the book is opened.

### Durable against Temperature

PUR hotmelt glue retains durability and flexibility in both high and low temperatures. The temperature resistance for PUR hotmelt glue ranges from -20 to 120 degrees Celsius versus 0 to 60 degrees Celsius for EVA hotmelt glue. This allows PUR bound books to be handled in almost any climate or location.

### Ecology

PUR adhesive is environmentally friendly, allowing PUR-bound books to be recycled. PUR also has a lower melting point (120 degrees Celsius) than EVA for operational energy savings.

\*PUR hotmelt is reactive glue and takes time to become solidified. Contact your local dealer about required system components for binding with PUR hotmelt glue.

### pXnet System

## Manage your bindery with JDF enabled control system.



The Horizon pXnet Bindery Control System is used as a central control point to schedule work, send job data to each finisher, monitor status of finishers and collect production statistics from finishers in real-time. pXnet brings efficiency and value in high-mix/low-volume production environments where frequent job changeovers are needed.

The pXnet system can also be interfaced with an existing workflow for automated JDF set-up.

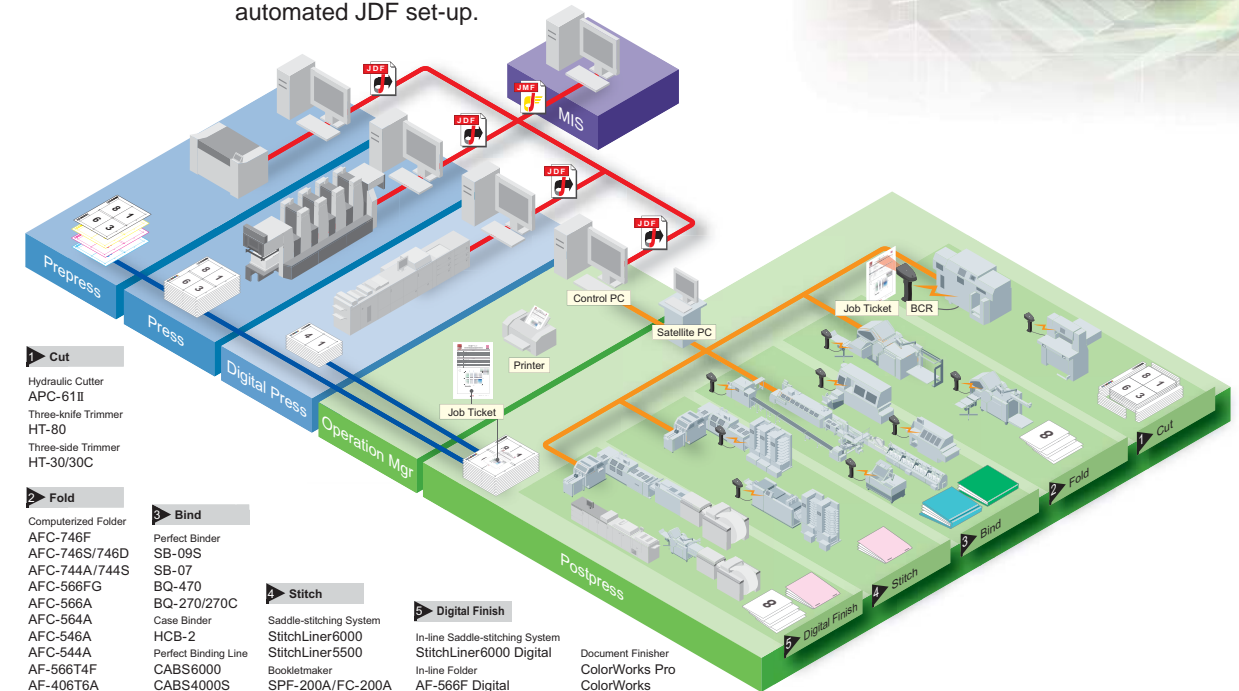

## CABS4000S Floor Plans

### MG-600+SB-09S+HT-110 Connected

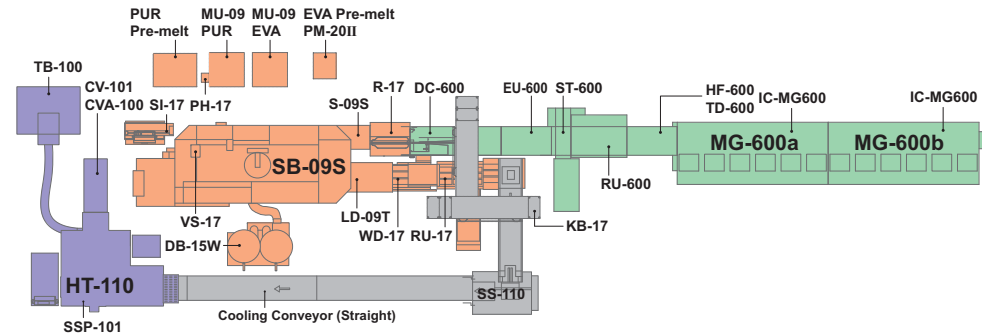

### MG-600+SB-09S Connected

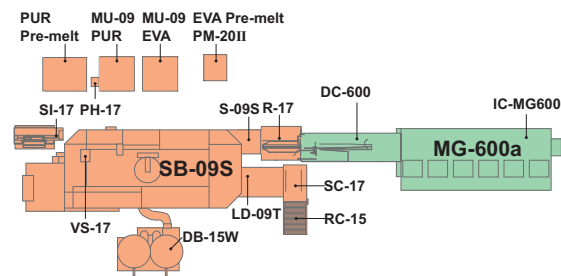

### MG-600+SB-09S+HT-110 Connected

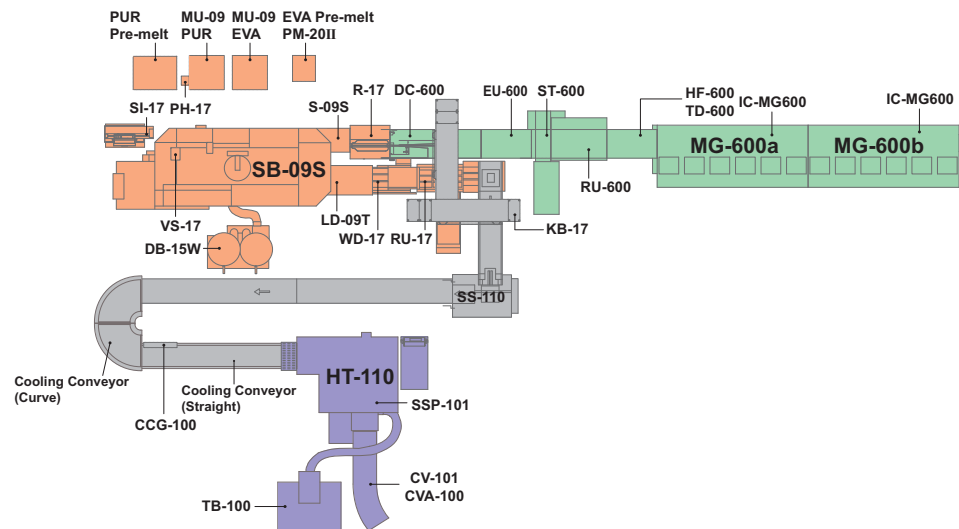

### SB-09S Stand alone

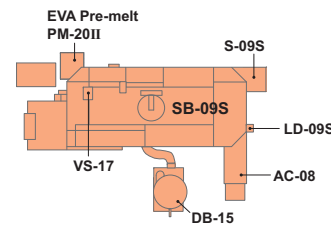

### MG-600 Stand alone

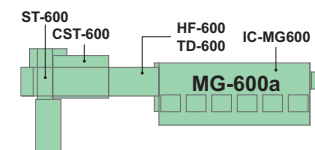

### HT-110 Stand alone

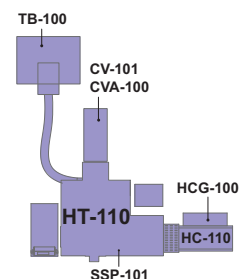

## CABS4000S Components

System Gatherer MG-600			
Model name	Description	Remarks	
EU-600	Extra connecting unit	EU-600 is needed between MG-600 and SB-09S when WD-17 is installed.	
IC-MG600	Image checker	Image checking cameras check the image of each signature to prevent incorrect loading.	
TD-600	Book block thickness detector	TD-600 detects the thickness of gathered signatures installed on HF-600.	
ST-600	On/Off-line stacker	MG-600 is possible as stand alone .	
RU-600	Book block rejecting unit	Incorrect signatures are rejected for non-stop operation.	
HF-600	Hand feed unit for MG-600H	HF-600 allows an operator to hand feed additional signatures or sheets.	
Selection	DC-600	Docking conveyor unit	DC-600 is connecting unit between MG-600 and SB-09S.
	CST-600	Connecting unit	CST-600 is docking unit for MG-600 and ST-600 off-line.
	CU-600	Docking conveyor unit	CU-600 is needed when using MG-600 with RU-600 as off-line, but possible to expand to SB-09S on-line.

System Binder SB-09S				
Model name	Description	Remarks		
Selection	R-17	Connecting belt unit	Connecting unit between MG-600 and SB-09S	
	S-09S	Automatic feed unit	In-feeder unit for collated book block set	
	U-09S	Manual feed unit	Manual feed unit for collated book block set, not possible to expand to MG-600	
	DB-15	Milling blower unit (Single)	Single type milling waste collecting unit	
	DB-15W	Milling blower unit (Twin)	Twin type milling waste collecting unit	
PM-20II	Pre-melt tank	Pre-melt automatic feeding tank for EVA (18 liters) (Contact your local dealer about pre-melt tank for PUR.)		
CN-09	Pre-melt tank nozzle	Pre-melt tank nozzle set for SB-09S		
VS-17	Smoke extractor unit	Smoke extractor for SB-09S		
MU-09EVA	Melt tank unit for EVA glue	MU-09EVA is used for EVA glue application. (Drum rollers application)		
MU-09PUR	Melt tank unit for PUR glue	MU-09PUR is used for PUR glue application (open drum). (Drum rollers application)		
PH-17	Pre-tank-heater	PH-17 is used to heat up the EVA unit MU-09EVA or PUR unit MU-09PUR for short-make-ready of glue tank change.		
SI-17	Book/Cover sheet size input interface	SI-17 measures the book block and cover sizes, and sends the data to SB-09S.		
Set	LD-09S	Chute delivery conveyor	Chute delivery conveyor for AC-08	
	AC-08	Slope conveyor	Length 1.0 m	
	LD-09T	Twisting conveyor	Twisting conveyor for SC-17, SCH-15 or HT-110	
	Set	SC-17	Stack conveyor	When not using HT-110, SC-17 is needed as delivery unit.
	Set	RC-15	Delivery roller conveyor unit (1 m)	Delivery roller conveyor unit for SC-17
Set	SCH-15	Delivery stacker	When not using HT-110, SCH-15 is needed as delivery unit.	
Set	CV-101	Delivery roller conveyor unit (1 m)	Delivery roller conveyor unit for SCH-15	
WD-17	Weight checking unit	WD-17 checks weight of each book.		
RU-17	Book rejecting unit	RU-17 rejects a faulty book detected on WD-17.		

Connecting Delivery Section		
Model name	Description	Remarks
SS-110	Stack stream unit	Bound books are transported into the stack stream orientator (SS-110) to accumulate a predetermined number of books (up to 100 mm) for trimming in HT-110. LD-09T is required.
KB-09	Bridge	Bridge over delivery section
KB-17	Bridge	Bridge over delivery section This is needed when MG-600, SB-09S, and HT-110 are connected.
-	Cooling conveyor	Various configurations are arranged depending on space requirements. Longer cooling conveyor is needed when PUR glue application is used.
CCG-100	Guide for curve conveyor	The guide for adjusting position of delivered book on the cooling conveyor

Three-knife Trimmer HT-110			
Model name	Description	Remarks	
HC-110	Hand feed conveyor	HC-110 is needed to feed books when HT-110 is used as stand alone. HC-110 is 1.3 m length conveyor and its speed can be adjusted in three phases.	
HCG-100	Hand feed guide set	Guide set for delivered books, installed at the entrance section of HT-110 on the cooling conveyor	
-	Cutting table and clamber plate	Cutting table and clamber plate for each size	
Selection	CV-101	Delivery roller conveyor	CV-101 is 1 m length of Roller conveyor for delivery section HT-110.
	CVA-100	Delivery extension conveyor	CVA-100 extension conveyor which can be extended from 1.5 m to 3.8 m
SSP-101	Automatic silicon spraying system	SSP-101 sprays Silicon to top-Bottom knives to inhibit glue from sticking to the knives while trimming. Recommended to use when PUR glue application is used	
TB-100	Trimming waste extractor unit	TB-100 uses air blowering for the trimming waste.	

- Set : Need to have both unit as a set.

- Selection : Select one of the option.



\*Contact your local dealer for more information.

## Machine Dimensions and Configuration Examples [Unit : mm (inch)]

### Example 1

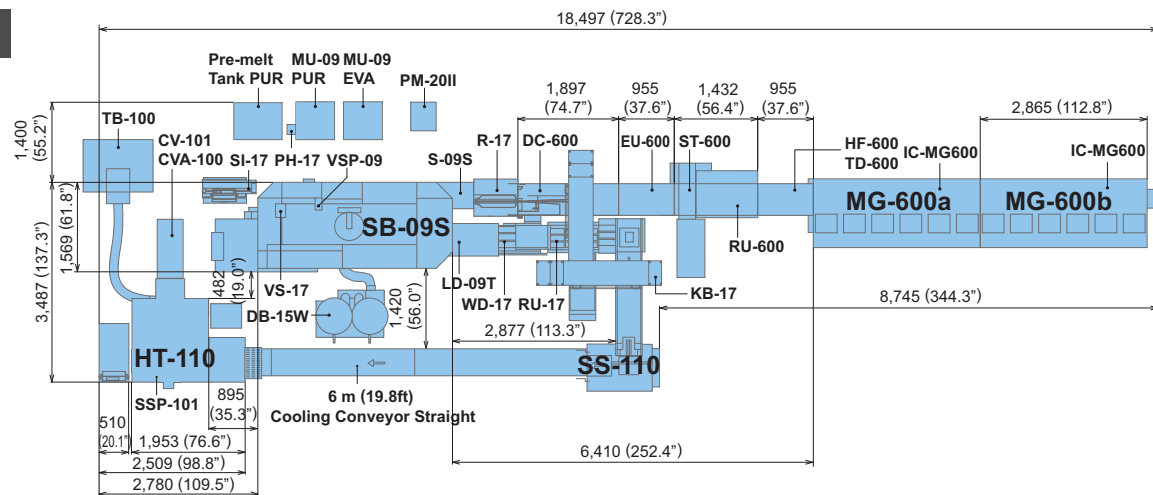

### Example 2

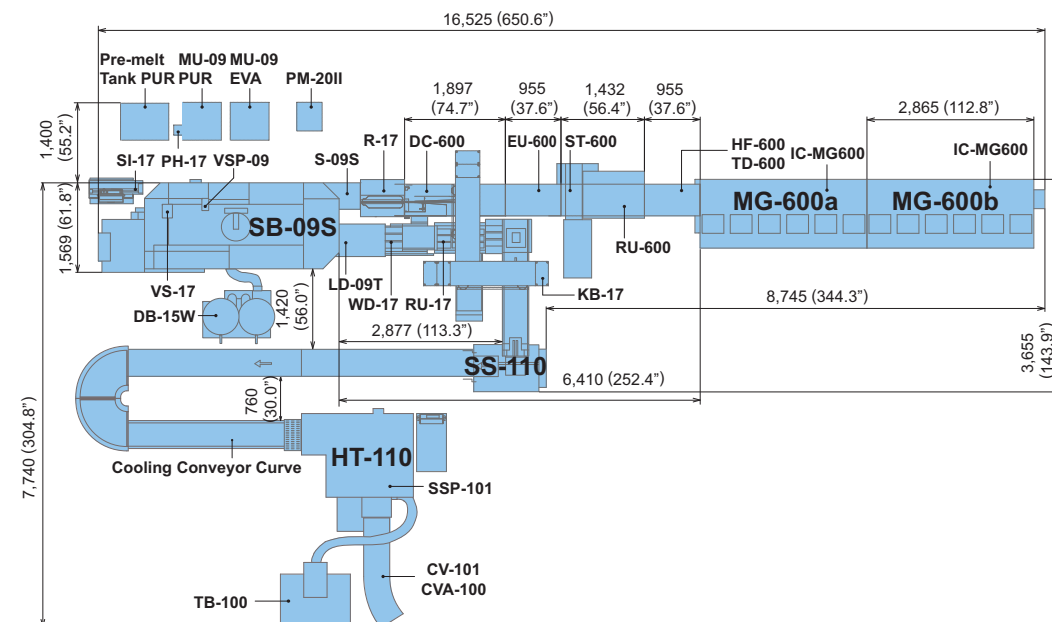

## Specifications

MG-600 Specifications	
Sheet Feeding System	Air suction bottom feed
Module Configuration	MG-600a / MG-600b / MG-600c / MG-600c / MG-600b / MG-600b
Number of Hopper	6 hoppers / 12 hoppers / 18 hoppers / 24 hoppers / 30 hoppers / 36 hoppers
Sheet Size	Max. 385(L) x 275(H) mm (15.15" x 10.82") Min. 148(L) x 105(H) mm (5.83" x 4.14")
Bin Pile Height	Normal paper signature: Max. 300 mm (11.81") Coated paper signature: Max. 150 mm (5.90")
Max. Transport Thickness	Max. 50 mm (1.96")
Sheet Weight Range	Normal signature sheet
Production Speed	Max. 6,000 sets/hr.
Power Consumption	MG-600a: 50 / 60 Hz, 2.9 kW / MG-600b: 50 / 60 Hz, 1.8 kW MG-600c: 50 / 60 Hz, 2.7 kW
Machine Dimensions	MG-600a: 3,200(W) x 1,180(D) x 1,690(H) mm (126.0" x 46.5" x 66.6") MG-600b/c: 2,860(W) x 1,180(D) x 1,690(H) mm (112.6" x 46.5" x 66.6")

HT-110 Specifications	
Untrimmed Book Size (Top-Bottom x Fore-edge)	Max. 410 x 320 mm (16.14" x 12.59") Min. 148 x 105 mm (5.83" x 4.14")
Trimmed Book Size	Max. 366 x 300 mm (14.40" x 11.81") Min. 145 x 103 mm (5.71" x 4.05")
Trimming Width	Fore-edge: 45 mm (1.77") (Maximum trim width for fore-edge is 23 mm / 0.90" when the finishing size is A4E-Landscape.) Top-Bottom: 30 mm (1.18")
Trim Thickness	2 to 100 mm Limitations: a. Max. 50 mm (1.96") for books which measure 145 mm (5.71") or shorter between spine and fore-edge b. Limitation for books which have a finished length of 325 mm (12.80") or longer between top and bottom For example: Max. 55 mm (2.16") for books which measure 400 mm (15.74") between top and bottom before trimming Max. 80 mm (3.14") for books which have a length of 364 mm (14.33") between top and bottom before trimming
Clamp and Pressure	4 kN to 12 kN (Adjustable in 9 steps)
Production Speed	400 to 1,600 cycles (Adjustable in 13 steps)
Power Consumption	200 V, 50 / 60 Hz, 3.9 kW Compressor not included
Machine Dimensions	Main Body: 1,950(W) x 2,150(D) x 1,950(H) mm (76.8" x 84.7" x 76.8") Power Box: 508(W) x 1,000(D) x 1,450(H) mm (20.0" x 39.4" x 57.1")

\*The machine design and specifications are subject to change without any notice.

SB-09S Specifications	
Max. Book Size	Automatic In-Feed Max. including from MG-600 Portrait: 330(L) x 250(H) mm (12.99" x 9.84") Direct Feed to clamper Max. Portrait: 400(L) x 280(H) mm (15.74" x 11.02") Land Scene: 330(L) x 320(H) mm (12.99" x 12.59")
Min. Book Size	Automatic In-Feed Min. including from MG-600 Portrait: 148(L) x 105(H) mm (5.83" x 4.14") (A6) Direct Feed to clamper Min. Portrait: 148(L) x 105(H) mm (5.83" x 4.14") (A6) Land Scene: 135(L) x 185(H) mm (5.32" x 7.29") (B6)
Book Thickness	1 to 45 mm (0.04" to 1.77") Depends on condition
Cover Size (Top-Bottom x Fore-edge)	Max. Top-bottom 400 x Fore-edge 660 mm (15.74" x 25.98") Min. Top-bottom 135 x Fore-edge 220 mm (5.32" x 8.67")
Cover Weight Range	82 to 302 gsm Normal Paper, 105 to 348 gsm Coated Paper
Cover Pile Height	Max. 130 mm (5.1")
Production Speed	Max. 4,000 books/hr.
Machine Dimensions	Stand alone (with U-09S, AC-08) 4,520(W) x 2,425(D) x 1,660(H) mm (178.0" x 95.5" x 65.4") System (with U-09S) 4,900(W) x 1,570(D) x 1,660(H) mm (193.0" x 61.9" x 65.4")

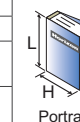

Portrait

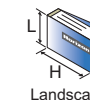

Landscape

think intelligent automation.

\*The machine design and specifications are subject to change without any notice.

---

Distributed by

**HORIZON INTERNATIONAL, INC.**

510 Kuze Ooyabu-cho, Minami-ku, Kyoto, 601-8206, Japan Phone : +81-(0)75-934-6700, Fax : +81-(0)75-934-6708, [www.horizon.co.jp](http://www.horizon.co.jp)

110318/SO/CABS4000S/00E/TV