

**Horizon**

# BQ-160



Professional quality books with a simple process.  
Up to 40mm (1.6") thick books can be bound.



## A Perfect Finishing Solution for On Demand Production!

Simple touchscreen operation and an efficient binding procedure achieves production rates up to 180 books/hour.



### 1 Color Touchscreen

A graphical icon-based color touchscreen is provided for easy set-up and operator navigation.



#### Ecology functions:

Power saving mode (stand-by mode): If the system is not used for a predetermined period, the glue tank heater will automatically adjust to a lower temperature.

Auto shut down mode: If the system is not used for a predetermined period of time, the system automatically shuts down.

### 4 Glue Tank Section

Uniquely designed glue tank ensures superior glue application to the book spine for quality binding.



### 5 Nipping Section

Strong nipper mechanism ensures quality book binds. Nipping pressure, nipping height and angle can be adjusted from the touch screen.



Nipper setting screen



### 2 Clamper Section

The clamp opens and closes with the simple press of a button for operator convenience.

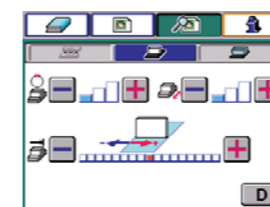

Clamper setting



### 6 Cover Section

Perfect binding, tape binding and padding can be performed. Tape width can be adjusted automatically by selecting desired width from the touchscreen.



Perfect binding setting

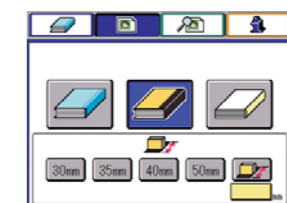

Tape binding setting



### 3 Notching Section

The double-pass notching function produces strong book binds. Notching can be easily set ON or OFF from the touchscreen.

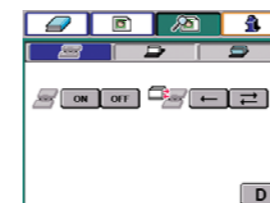

Notching setting



## Simple Operation

### Quick and Easy Production Steps.

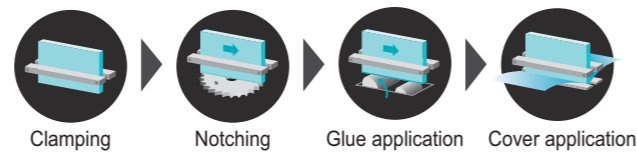

1 Insert the book block and press the start button.



2 Place the cover and press the start button again.



3 Glue is applied on the spine of the book.



4 A cover is applied and book binding is completed.

## BQ-160 Major Specifications

Binding Mode	Binding with cover sheet, Padding and Binding without tape
Number of Carriage Clamps	1
Book Block Size (Top-Bottom x Fore-edge)	Max. 350 x 300 mm (13.7" x 11.8") Min. 70 x 128 mm (2.8" x 5.1")
Book Thickness	1 to 40 mm (0.04" to 1.6")
Cover Size (Top-Bottom x Fore-edge)	Max. 350 x 640 mm (13.6" x 25.1") Min. 70 x 256 mm (2.8" x 10.1")
Cover Weight Range	82 to 302 gsm (22 to 80 lb)
Production Speed	120 books/hr. (Padding) 180 books/hr. (Perfect Binding)
Voltage / Frequency	Single Phase 115 V, 50 / 60 Hz Single Phase 230 V, 50 / 60 Hz
Machine Dimensions	1,370(W) x 540(D) x 1,280(H) mm (53.9" x 21.2" x 50.4")

\*The machine design and specifications are subject to change without any notice.

## Machine Dimensions [Unit : mm (inch)]

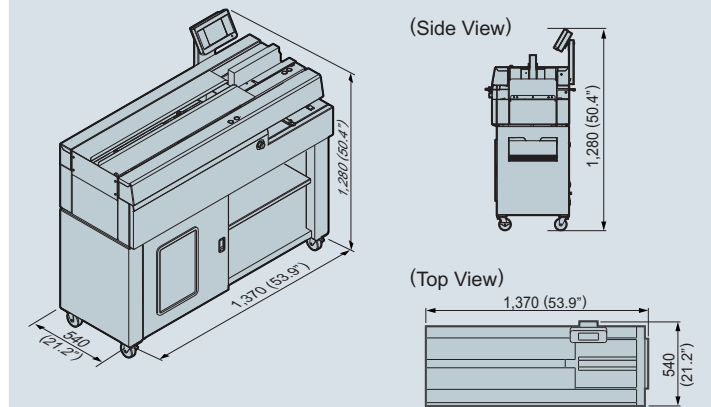

## Wide ranges of perfect binders are available

**BQ-P60** : Tabletop Perfect Binder



**BQ-270C** : Single-Clamp Binder



**BQ-470** : 4-Clamp Binder



### Major Specifications

	BQ-P60	BQ-160	BQ-270C	BQ-470
Binding Mode	Binding with cover sheet, Padding and Binding without tape	Binding with cover sheet, Padding and Binding without tape	Binding with milling, Binding without milling and Padding	Binding with milling, Binding without milling and Padding
Number of Carriage Clamp	1	1	1	4
Book Block Size (Top-Bottom x Fore-edge)	Max. 315 x 210 mm (12.4" x 8.2") Min. 210 x 148 mm (8.3" x 5.9")	Max. 350 x 300 mm (13.7" x 11.8") Min. 70 x 128 mm (2.8" x 5.1")	Max. 320 x 320 mm (12.5" x 12.5") Min. 135 x 105 mm (5.4" x 4.2")	Max. 320 x 320 mm (12.5" x 12.5") Min. 145 x 105 mm (5.7" x 4.2")
Book Thickness	Max: 25 mm (0.9")	1 to 40 mm (0.04" to 1.6")	1 to 50 mm (0.04" to 2.0")	1 to 65 mm (0.04" to 2.56")
Production Speed	Max. 180 books/hr.	Max. 180 books/hr.	Max. 500 cycles/hr.	Max. 1,350 cycles / hr. (EVA) Max. 1,000 cycles / hr. (PUR)

Distributed by

**HORIZON INTERNATIONAL, INC.**

510 Kuze Ooyabu-cho, Minami-ku, Kyoto, 601-8206, Japan Phone : +81-(0)75-934-6700, Fax : +81-(0)75-934+6708, www.horizon.co.jp